

TENTEC AERO WT BOLT TENSIONERS FOR WIND TURBINES



The worldwide standard for wind turbine
bolt tensioning tools.

Atlas Copco



TENTEC AERO WT BOLT TENSIONERS FOR WIND TURBINES

We offer a range of Tentec bolt tensioning equipment specially designed for use on Wind Turbines.

The Aero WT range comprises of bolt tensioning tools suitable for a complete wind turbine bolting installation or maintenance programme on many different types and models of wind turbines.

By listening to customer requirements these feature rich, powerful bolt tensioning tools are packed full of operator requested features including quick release swivel fittings, automatic piston return and intuitive operation.

The products are manufactured from aircraft quality high strength tensile steel and are compact and lightweight for ease of handling.

Support

Tentec bolt tensioning tools have been supplied to the wind industry for over 15 years. We have developed a class leading support and advise system

- Quick Delivery, Local Stock*
- On-Site Support, Telephone Support*
- On-Site Training, Technical Advice*
- Easy On-Site Tool Maintenance*

Safety & Reliability

Integrated into the design of Aero WT tensioners are multiple enhanced safety features including mechanisms to remove the hazard of premature puller failure. In addition we have developed a class leading high pressure seal technology. This mature seal technology is industry proven and offers many 1000's of reliable and safe pressure cycles.

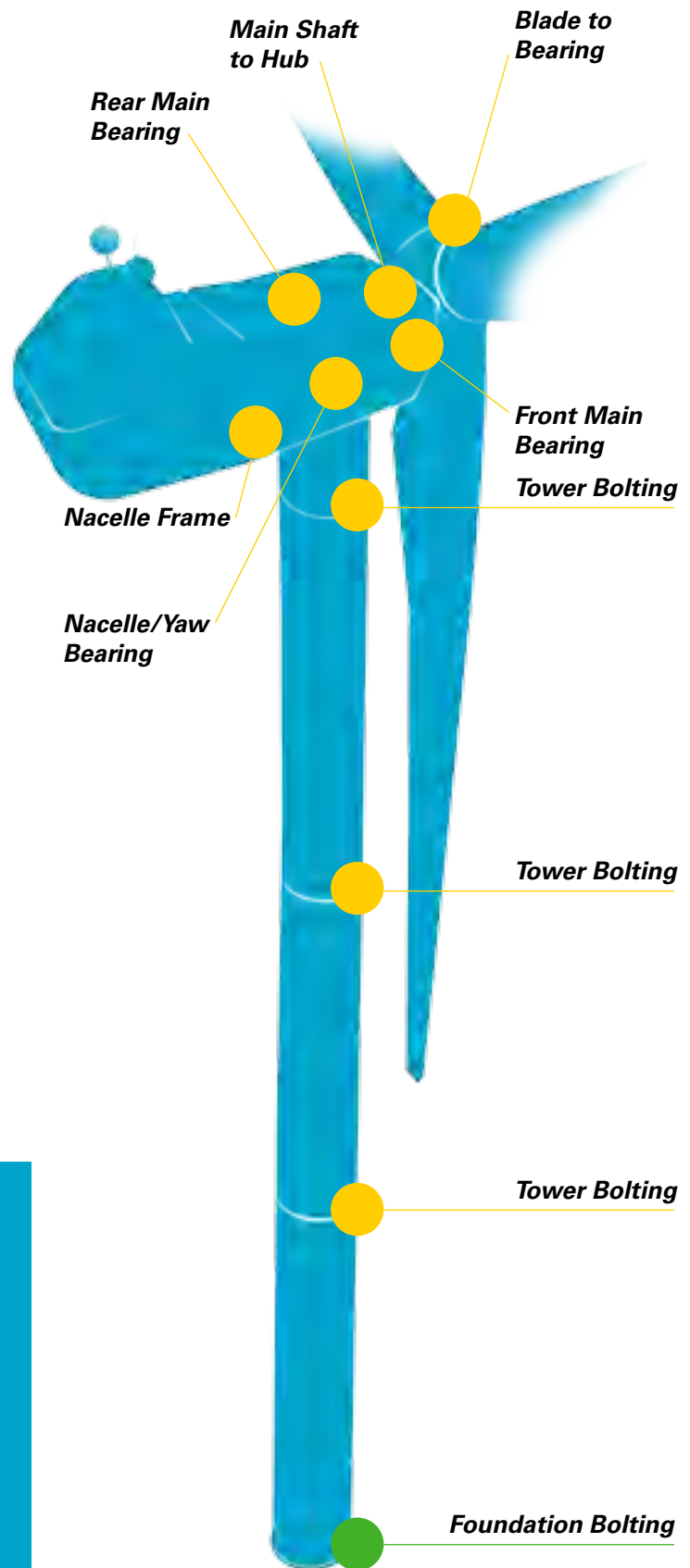

 **WTB Series**

 **WTF Series**

BOLT TIGHTENING SOLUTIONS

Why Use AERO WT - Wind Turbine Tensioners?

Real World Experience

Tentec Aero WT tensioners have been continually developed over a 15 year period. We know all the difficulties associated with wind turbine bolt tensioning. Every design feature of these tools is there for a good reason.

Versatile

The Aero WT Series consists of a purpose designed tools for every bolted joint on a Wind Turbine.

Adaptable

Aero WTB Tensioners are profile cut at the base to ensure they fit onto as many applications as possible. This interchangeable profile cut spacer gives the tensioner the flexibility to be used on many different applications.

TENTEC AERO WTB TENSIONERS

Fully aware of the difficulties associated with wind turbine blade tensioning, the new Tentec Aero WTB is a purpose designed range of hydraulic bolt tensioning tools to suit most wind turbine bolting applications. All WTB Tensioning tools have the capacity to achieve the specified proof load requirements as detailed in EN ISO 898-1:1999 and ASTM A490M for grade 10.9 Bolts. These feature packed tensioners have been designed with rapid tensioning in mind and offer a safe, reliable and consistent method to simultaneously tension many bolts.

BOLT TIGHTENING SOLUTIONS

Aero WTB Applications

- Rear Main Bearing
- Nacelle Frame
- Nacelle/Yaw Bearing
- Blade to Bearing
- Front Main Bearing
- Intermediate Tower Bolting

Features & Benefits

Automatic Reset

Internal heavy duty springs automatically resets the tensioner once the pressure has been released.

High Life Puller

All Aero WTB tensioners have a device that ensures the tool fails safely in the unlikely event of a puller failure

"Snap Down" Nut Drive

To increase speed all Aero WTB tensioners are fitted with a spring loaded device that automatically engages the tensioner drive socket with the hexagon nut.

Grip Surface

For easy user handling

Optional Cycle Counter

For maintenance scheduling purposes all Aero WTB Tools offer an optional mechanical pressure cycle counter.

Swivel Connection

360° swivel operation allows the hydraulic hoses to be positioned in the best possible position to allow open access to the tensioning tools.

Geared Nut Run Down

The inclusion of a gear nut run-down mechanism offers a very rapid and consistent way of seating the hexagon nuts during the tensioning procedure

Best Fit

The interchangeable profile cut spacer at the base of the tool gives the tensioner the flexibility to be used on many different applications.



"Snap Down" Nut Drive



Automatic Reset



Best Fit

TENTEC AERO WTB TENSIONERS

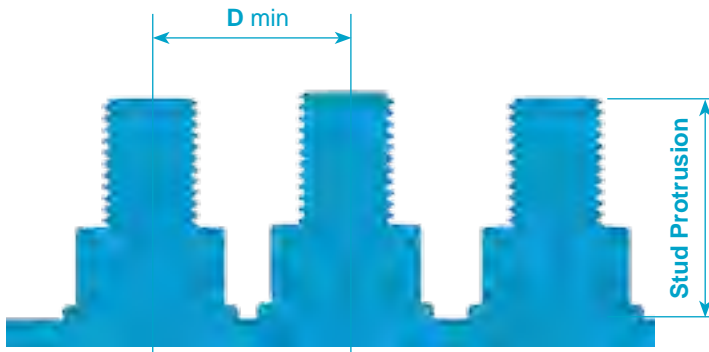

Maximum Working Pressure =1350 bar :19580psi

Ident	Bolt Diameter	Stud Protrusion (mm)		Max Stroke	Maximum Load		Hydraulic Pressure Area		Dia A	Height B	D	Weight
		Min	Max		mm	kN	lbs	mm2				
	Metric			mm	kN	lbs	mm2	In2	mm	mm	mm	kg
WTB30	M30	59	69	8	465.38	104622	3447.21	5.343	72	205	64	6.16
WTB33	M33	64	73	10	575.80	129444	4265.09	6.611	79	217.5	71	7.24
WTB36	M36	71	81	10	678.26	152478	5024.05	7.787	84.5	229.5	77	8.75
WTB39	M39	76	86	10	810.58	182225	6004.20	9.307	92	263	83	11.12
WTB42	M42	83	93	10	929.67	208999	6886.37	10.674	97	262.5	95	12.75
WTB45	M45	88	98	10	1079.48	242682	7996.12	12.394	105	275.5	94.5	15.86
WTB48	M48	94	104	10	1221.57	274620	9048.67	14.025	111	286.5	100.5	17.84
WTB56	M56	110	120	10	1686.19	379070	12490.29	19.359	132	314	115	26.5
WTB64	M64	124	134	10	2221.00	499300	16461.30	25.515	150	352	124	35

TENTEC AERO WTB - LOW HEIGHT

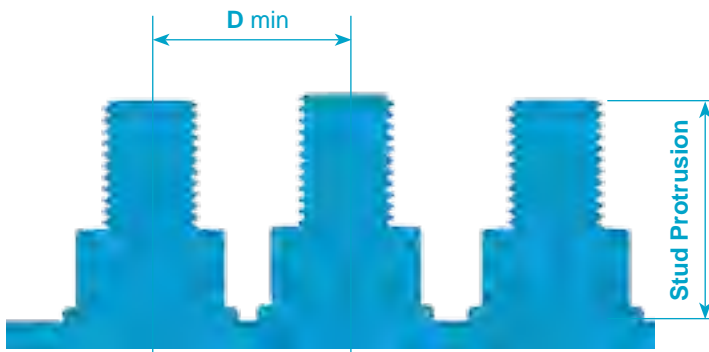

Maximum Working Pressure =1350 bar :19580psi

Ident	Bolt Diameter	Stud Protrusion (mm)		Max Stroke	Maximum Load		Hydraulic Pressure Area		Dia A	Height B	D	Weight
		Min	Max		mm	kN	lbs	mm2				
	Metric			mm	kN	lbs	mm2	In2	mm	mm	mm	kg
WTBLH36	M36	71	91	10	678.14	152452	5023.4	7.79	123	167.5	-	9.97
WTBLH42	M42	83	103	10	930.15	209106	6889.96	10.68	142.5	181.3	-	13.94

BOLT TIGHTENING SOLUTIONS

We have many years experience of designing bespoke bolt tensioning tools for instances where standard tools are not suitable. Contact us for more information



TENTEC AERO WTF TENSIONERS

The Tentec Aero WTF is a purpose designed range of hydraulic bolt tensioning tools developed and designed to suit most wind turbine foundation bolting applications. The Aero WTF tensioning tools can be supplied to suit many different All Thread Bars and the more conventionally ISO metric and Imperial Unified thread forms. These feature packed tensioners have been designed with rapid tensioning in mind and offer a safe, reliable and consistent method to simultaneously tension many foundation bolts. The Tentec Aero WTF range of tensioning tools have been fully site evaluated in the wind energy industry.

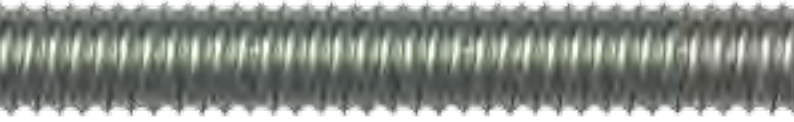
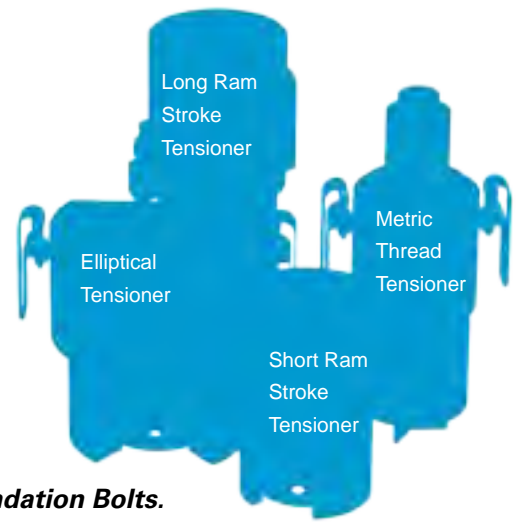

Suitable Load Capacity for Grade 75ksi & 150ksi - All Thread Foundation Bolts.

Features & Benefits

Long Ram Stroke

The Aero WTF range of tensioners offer up to 25mm piston/ram stroke capability

Seal Reliability

Class leading high pressure seal technology

Handling Straps

For easy user handling

"Snap Down" Nut Drive

To increase speed all Aero WTF tensioners are fitted with a spring loaded device that automatically engages the tensioner drive socket with the hexagon nut.

Swivel Connection

360° swivel operation allows the hydraulic hoses to be positioned in the best possible position to allow open access to the tensioning tools.

Geared Nut Run Down

The inclusion of a gear nut run-down mechanism offers a very rapid and consistent way of seating the hexagon nuts during the tensioning procedure



25mm(1") Ram stroke for 'One Pull' Tensioning

Due to the unusual length of foundation bolts and the methods used to anchor the bolts into the foundation structure, it is usual to experience relatively large amount of bolt extension during foundation bolt tensioning. For this reason it is very important that the bolt tensioning tool used has plenty of piston/ram stroke capacity. The Aero WTF range of tensioners offer up to 25mm piston/ram stroke capability for "One Pull" uninterrupted tensioning. Shorter stroke foundation tensioners are available from Tentec to be used where bar protrusion is limited.

Long Stud Protrusion Models

The amount of thread protruding from a foundation bolt nut can vary significantly from turbine to turbine. To overcome this variation the Aero WTF Bolt tensioning tool is available in both short and long stroke variations. An elliptical WTF tool is also available for use when clearance between the bolt and tower wall is restricted.

Short Stud Protrusion Models

When the stud protrusion is limited, the long stroke tensioners may not be suitable, in this instance a short stroke WTF tensioner is available.

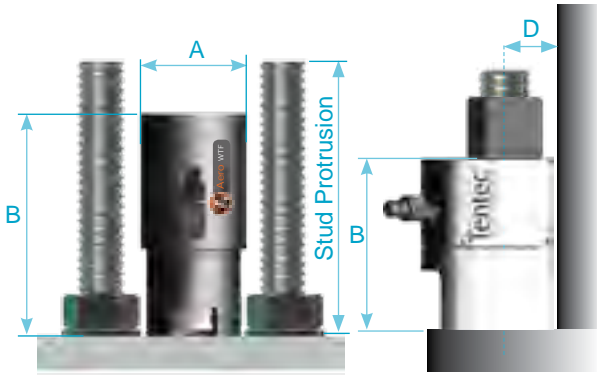

Technical Specification - WTF

BOLT TIGHTENING SOLUTIONS TENTEC Aero WTF Models

- Long Ram Stroke Tensioner
- Short Ram Stroke Tensioner
- Metric Thread Tensioner
- Elliptical Tensioner

Maximum Working Pressure = 1350bar :19580psi

75 KSI - All Thread Bar													
Tool Ident	Foundation Bolt Type	Gear Box	Stud Protrusion (mm)		Max Stroke mm	Maximum Load		Hydraulic Pressure Area		Dia A mm	Height B mm	D mm	Weight kg
			#10	#11		kN	lbs	mm2	In2				
WTF-8041	Grade 75ksi All Thread	Y	260	257	25	472.6	106244.7	3500.72	5.426	110	231	56	10.84
WTF-8148	Grade 75ksi All Thread	N	260	257	25	472.6	106244.7	3500.72	5.426	110	231	56	10.47
WTF-8040	Grade 75ksi All Thread	Y	200	197	10	472.6	106244.7	3500.72	5.426	108	158	55	7.06
WTF-8147	Grade 75ksi All Thread	N	200	197	10	472.6	106244.7	3500.72	5.426	108	158	55	6.69
WTF-7566 Elliptical	Grade 75ksi All Thread	N	205	198	10	469.3	105502.8	3128.83	4.85	142	144	41	10

150 KSI - All Thread Bar													
Tool Ident	Foundation Bolt Type	Gear Box	Stud Protrusion (mm)		Max Stroke mm	Maximum Load		Hydraulic Pressure Area		Dia A mm	Height B mm	D mm	Weight kg
			1.3/8"	1.1/4"		kN	lbs	mm2	In2				
WTF-8342	Grade 150ksi All Thread	Y	270	275	25	762.45	171404.8	5647.79	8.754	125	245	63.5	14.34
WTF-8343	Grade 150ksi All Thread	N	270	275	25	762.45	171404.8	5647.79	8.754	125	245	63.5	14.34
WTF-8340	Grade 150ksi All Thread	Y	215	223	10	762.45	171404.8	5647.79	8.754	123	175	62.5	9.72
WTF-8341	Grade 150ksi All Thread	N	215	223	10	762.45	171404.8	5647.79	8.754	123	175	62.5	9.72

Metric Coarse Threads													
Tool Ident	Foundation Bolt Type	Gear Box	Stud Protrusion (mm)		Max Stroke mm	Maximum Load		Hydraulic Pressure Area		Dia A mm	Height B mm	D mm	Weight kg
			Max	Min		kN	lbs	mm2	In2				
WTF-9753	M36x4	Y	250	190	15	579.8	130344	3866	5.992	108	210	50.6	10.27
WTF-9426	M42x4.5	Y	250	199	15	788	177078	5251	8.139	124	210	62	13.25

Designs and specifications are subject to change without notice or obligation. Read all safety instructions in the manual before usage.

COMMITTED TO SUSTAINABLE PRODUCTIVITY

www.bolttighteningsolutions.com

Atlas Copco